



---

|  |  |  |
|--|--|--|
|  |  |  |
|  |  |  |

1)

---

---

---

|  |  |  |
|--|--|--|
|  |  |  |
|  |  |  |
|  |  |  |

|  |  |  |  |  |
|--|--|--|--|--|
|  |  |  |  |  |
|  |  |  |  |  |
|  |  |  |  |  |

|  |  |  |  |  |
|--|--|--|--|--|
|  |  |  |  |  |
|  |  |  |  |  |
|  |  |  |  |  |

(1)  
(2)

|  |  |  |  |
|--|--|--|--|
|  |  |  |  |
|  |  |  |  |

---

---

|  |  |  |  |
|--|--|--|--|
|  |  |  |  |
|--|--|--|--|

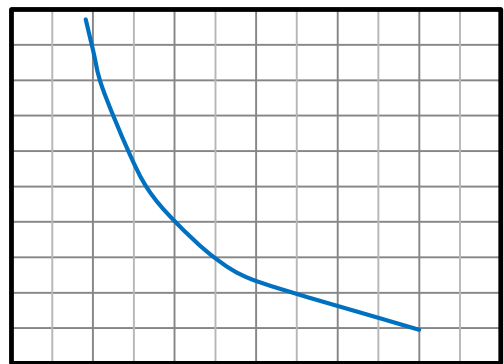
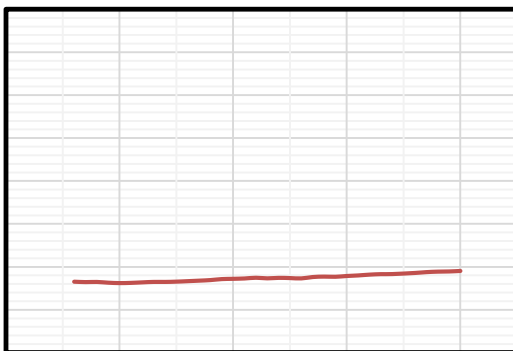
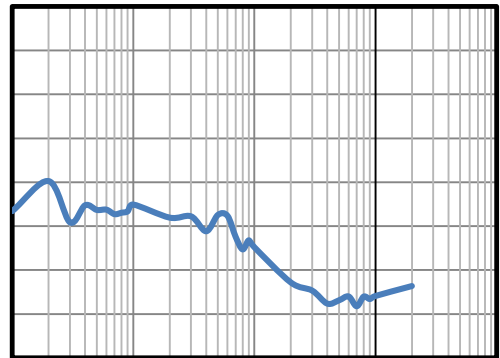
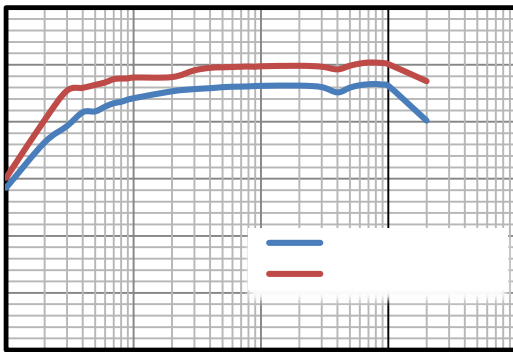
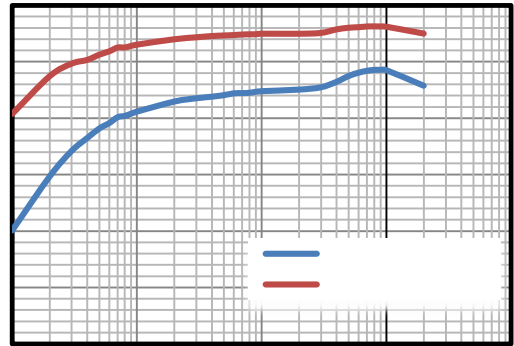
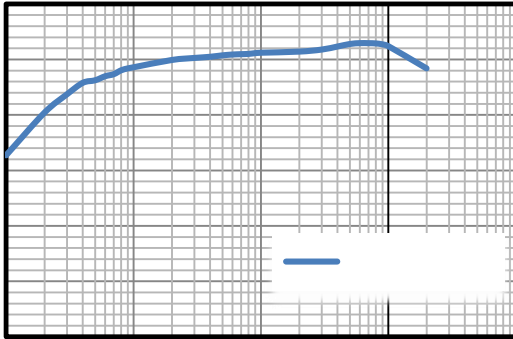



---

EN

FB

RT/CLK

Oscillator  
With PLL

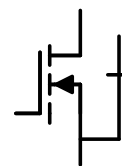
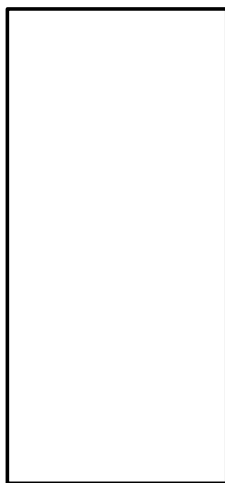





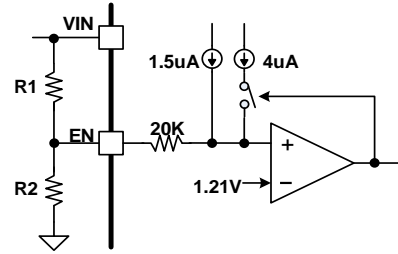

- 
- 

±1% tolerance



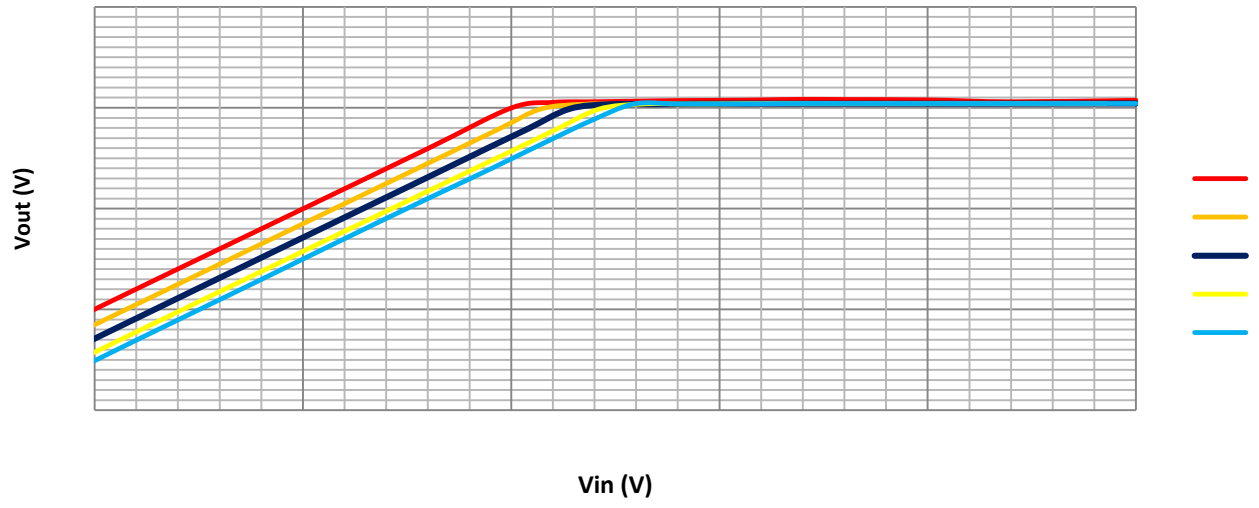

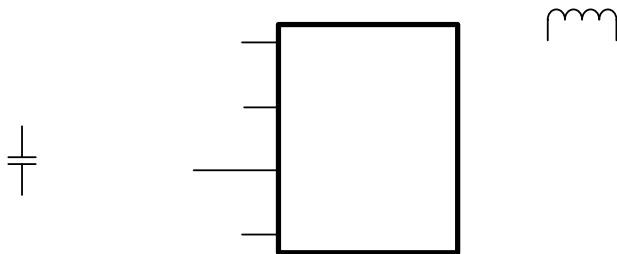

|  |  |
|--|--|
|  |  |
|  |  |
|  |  |
|  |  |
|  |  |
|  |  |
|  |  |
|  |  |
|  |  |
|  |  |



|  |  |  |
|--|--|--|
|  |  |  |
|  |  |  |
|  |  |  |
|  |  |  |
|  |  |  |
|  |  |  |
|  |  |  |
|  |  |  |

—

•

|  |  |
|--|--|
|  |  |
|  |  |
|  |  |
|  |  |
|  |  |

—

•

—

—

---

---

- 
- 
- 
- 
- 

---

- 
- 
- 
- 
- 
- 

---

---

---



- 
- - 
  - 
  - 
  - 
  -



- 
- 



- 
- 
- 





---

---

---

---

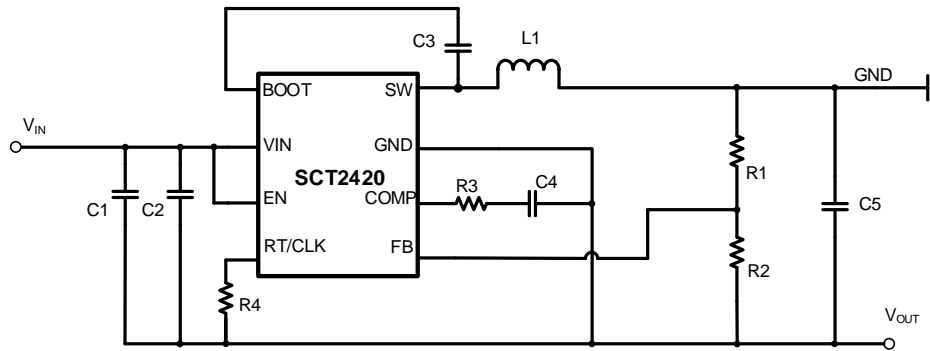

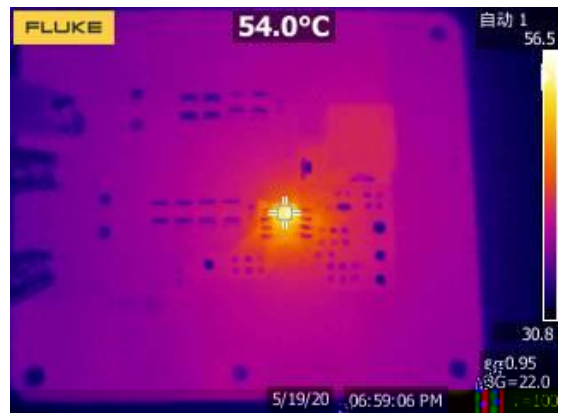
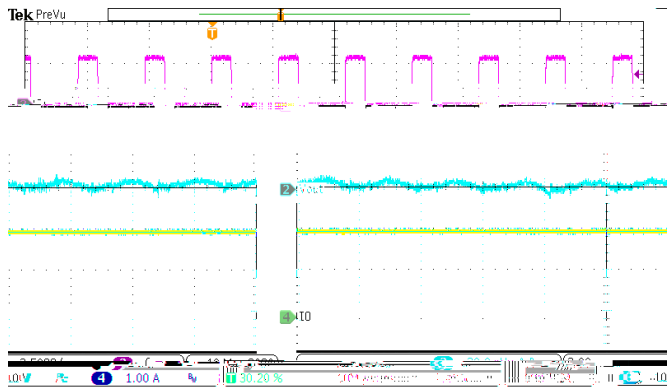
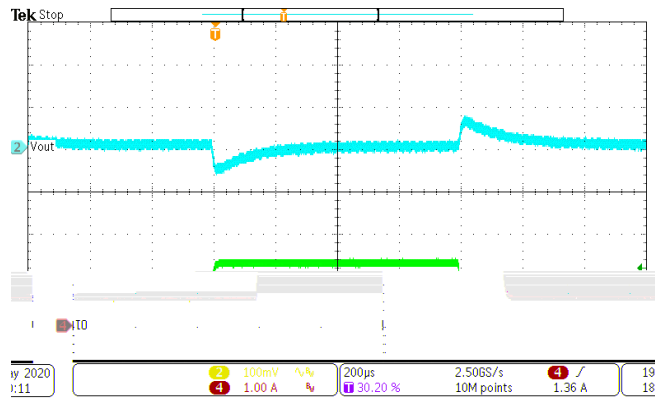
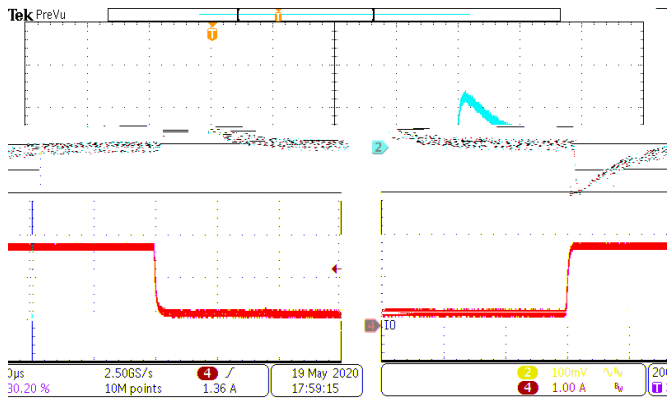
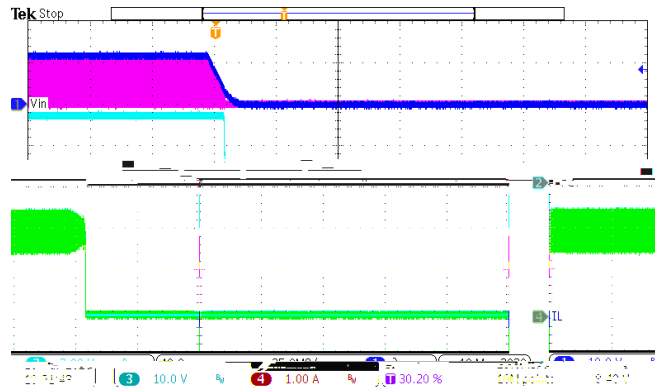
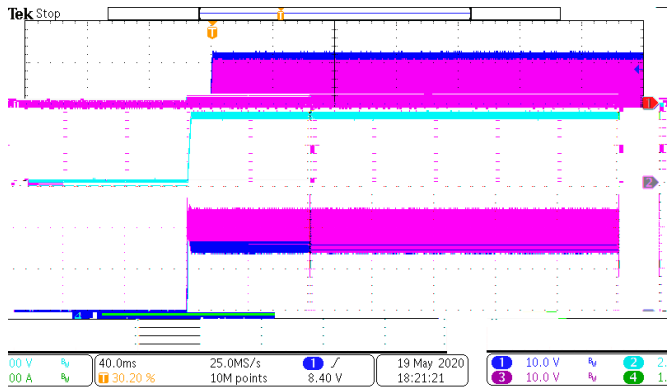

---



