

---

SCT8162X

If you have any questions please contact  
wesley-lin@silicontent.com  
sales@silicontent.com









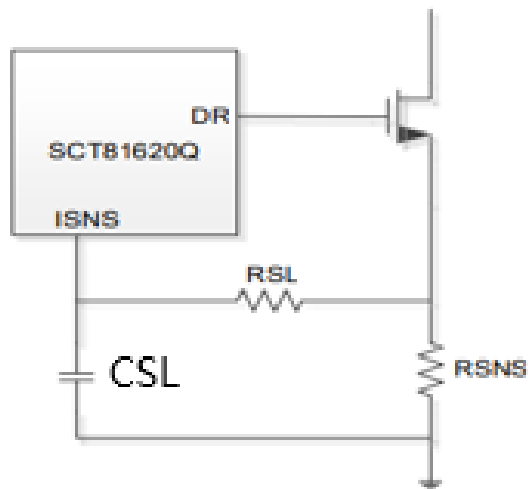









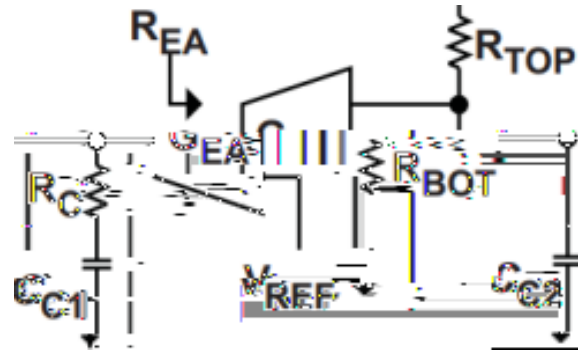

封装和脚数	产品	控制拓扑	最小输入电压(V)	最大输入电压(V)	静态电流(μA)	电流保护模式	开关频率(Hz)	抖频功能	封装
	<b>SCT81620</b>	升压, 反激, Sepic	3.2	50	450	Hiccup	100k-2.2M	√	MSOP-8
	<b>SCT81621</b>	升压, 反激, Sepic	3.1	50	415	Hiccup	100k-2.2M	√	MSOP-10
	<b>SCT81624</b>	升压, 反激, Sepic	3.1	50	415	恒流	100k-2.2M	-	MSOP-10
	<b>SCT81620Q</b>	升压, 反激, Sepic	3.2	50	450	Hiccup	100k-2.2M	√	MSOP-8
OP-10	<b>SCT81621Q</b>	升压, 反激, Sepic	3.1	50	415	Hiccup	100k-2.2M	√	MS
OP-10	<b>SCT81624Q</b>	升压, 反激, Sepic	3.1	50	415	恒流	100k-2.2M	-	MS